



# **LT-PT3300DC-X**

## **POWERTRAIN LIFT TABLE**

### **(DC BATTERY OPERATION)**

**3,300 lbs. Capacity (1497 Kg)**



## **ASSEMBLY & OPERATION MANUAL**

### **IMPORTANT!!**

**READ MANUAL THOROUGHLY BEFORE ASSEMBLING, OPERATING, OR MAINTAINING LIFT TABLE. WHEN COMPLETED WITH ASSEMBLY, ENSURE TO RETURN MANUAL & RELATED DOCUMENTS IN PROTECTIVE SLEEVE AND GIVE TO THE OWNER / OPERATOR.**

LT-PT3300DC-X  
MAR 2024

# Table of Contents

<b>1. Safety &amp; Cautions</b>	<b>Pages 3 - 4</b>
• Important Statements	
• Qualification of Operators and Users	
• Cautions	
• Training	
• Owners / Employer Responsibilities	
<b>2. Product Information &amp; Requirements</b>	<b>Pages 4 - 6</b>
• Description	
• Specifications	
• Dimensions	
• Receiving & Handling	
• Required Tools	
• Selecting Site	
<b>3. Assembly Instructions</b>	<b>Pages 7 - 8</b>
• Removal of Lift Table From Wooden Crate	
• Assemble Pallet Jack Dolly to Lift Table Base	
• Connecting Remote Hand Control Pendant to Control Box	
• Pre-Assembly From Factory Information	
• Battery Charging Information	
<b>4. Starting Up / Testing</b>	<b>Page 9</b>
• DC Battery System Operation Controls (Diagram)	
<b>5. Operation Instructions</b>	<b>Pages 10 - 11</b>
• Positioning, Lifting & Lowering Heavy Loads	
• PT Lift Table Feature Tips	
<b>6. Troubleshooting</b>	<b>Page 12</b>
<b>7. Inspection, Maintenance &amp; Cleaning</b>	<b>Page 13</b>
• Before Each Use (Pre-Operation Check)	
• Weekly Maintenance	
• Yearly Maintenance	
• Cleaning	
<b>Exploded Views &amp; 12VDC Circuit Diagram</b>	<b>Pages 14 - 17</b>
<b>Parts List</b>	<b>Pages 18 - 20</b>
<b>Limited Warranty Policy</b>	<b>Page 21</b>

# 1. Safety & Cautions

## Important Statements:

Please note the max weight capacity noted on the decal applied to side of the outer scissors and on the silver ID tag attached to the inner scissor. Do not try to lift any load that exceeds the rated lifting capacity. Please read this manual carefully before assembly and use of the lift table, to avoid any property loss or personal injury caused by faulty operation. No one is allowed to modify the controls, parts, or other mechanical parts of the machine without the manufacturer's permission.

## Qualification of Operators and Users:

- Only personnel who have received training are allowed to operate and use lift table.
- Non-professionals shall not approach the lifting area during use.

## Cautions:

- Do not use lift table on asphalt or any type of soft surface. Concrete thickness & strength must meet requirement to safely support lift table and the applied load.
- Please read and understand Safety Cautions carefully before operation of lift table.
- The lift table shall not be used outdoors if not customized to meet special water proofing requirements.
- Hands and feet shall be kept away from moving parts of the lift at all times.
- Only personnel who have received training are allowed to operate and use the lift table.
- Operators should not wear loose clothes to avoid being clamped by any moving part when the machine is descending or rising.
- Floors & surrounding area around lift table must be kept clean to help avoid accidents and possible lift table malfunctions or maneuvering issues.
- When possible, lower lift table onto safety latches after raising platform to the desired height, especially for heavy loads and/or for long time durations.
- Ensure the item(s) being raised & lowered are properly balanced & secured to platform.
- Check for any missing, broken, or seized parts or components that may contribute to improper wear & tear. Once any anomaly is detected, stop use immediately and contact the dealer.
- Always fully lower lift table prior to maneuvering to another location, loaded or unloaded.
- It is not allowed to modify any part of the lift without the manufacturer's permission.
- Anyone who will be in the vicinity of the lift table when it is in use should familiarize themselves with any **CAUTION**, **WARNING**, and **SAFETY** related decals supplied with this lift table. Replace if decals become illegible or missing.
- If the lift table is to stand idle for a long period of time, it is recommended the user shall:
  - a. Lower to minimum height & engage casters locks.
  - b. Shut the main power & control switches to the off positions.
  - c. Stow remote hand controller in utility / tool tray.
  - d. Lubricate moving parts.

## Training:

Lift table operators must be qualified & trained for safe use and proper operation, as described in Manual.

## Owner / Employer Responsibilities:

This is a lift table assembly / operation manual, and no attempt is made or implied herein to instruct the user in lifting methods particular to an individual application. Rather, the contents of this manual are intended as a basis for operation and maintenance of the unit as it stands alone or as it is intended and anticipated to be used in conjunction with other equipment.

Proper application of the equipment described herein is limited to the parameters detailed in the specifications and the usages set forth in the descriptive passages. Any other proposed application of this equipment should be documented and submitted in writing to the factory for examination. The user assumes full responsibility for any equipment damage, personal injury, or alteration of the equipment described in this manual or any subsequent damages.

## 2. Product Information

### Lift Table Description: (LT-PT3300DC-X)

The iDEAL LT-PT3300DC-X is a 3,300 lb. portable, high-rise commercial / industrial grade 12VDC battery powered electric-hydraulic lift table, incorporating a multi-adjustable powertrain platform primarily designed to assist with controlled lifting & lowering tasks to safely remove, replace or service heavy vehicle powertrain components such as engines, transmissions, drive-axle & transaxle assemblies, or other similar heavy components. The LT-PT3300DC-X comes standardly equipped incorporating a fully operational remote hand controller & control box panel buttons for dual operational control operations, while also including a high quality deep-cycle 12VDC sealed battery, integrated battery charger and 12VDC auxiliary outlet port. In addition, the iDEAL Powertrain 3300 lb. lift table comes standard with a pallet jack dolly with multi-directional poly casters, leg support stands, front locking swivel & directional poly casters, tool tray, double lift scissors, powerful DC electric motor and hydraulic pump, dual hydraulic cylinders, tie-down anchors, and heavy duty ratchet strap. Optional quick mount PT Support Stand Kit & 12VDC LED Spot Light with magnetic base also available.

### Specifications:

Lift Model	LT-PT3300DC-X
Capacity	3,300 lbs.
Overall Length	65.2"
Overall Width	33.5+
Max PT Platform Height	72"
Min PT Platform Height	35"
Dolly Hand Bar Height	47.2+
PT Platform Adj. Size (L x W)	31.5+to 36.7" x 23.6"
PT Platform Adj. Tilt Angle (+/-)	6° to 8°
PT Platform Locking Heights	49+, 61+, 68+
Lifting / Lowering Rate	20S / 22S
Power Supply (Battery Charger)	110VAC - 1.5A - 1PH
DC Power Unit	12VDC - 120A, 2.15HP
Ship Weight	908 lbs.

# Dimensions: (LT-PT3300DC-X)

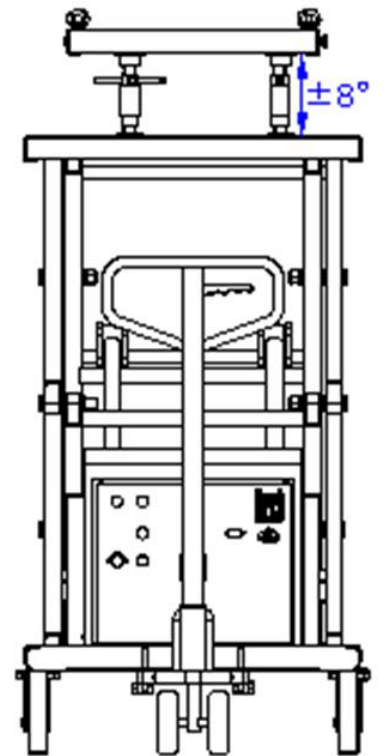
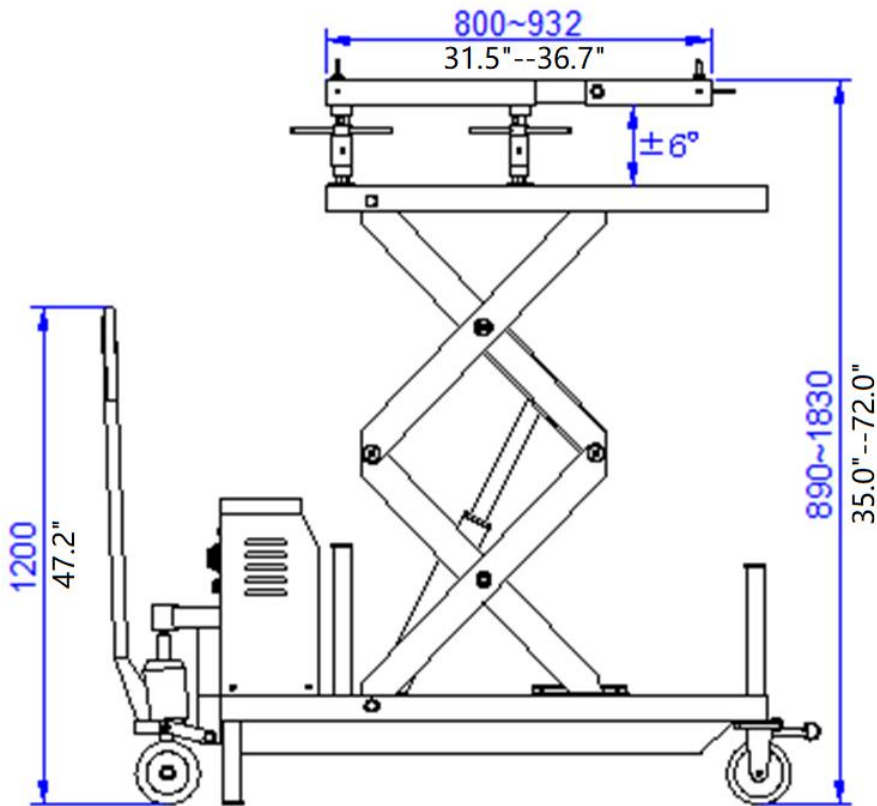
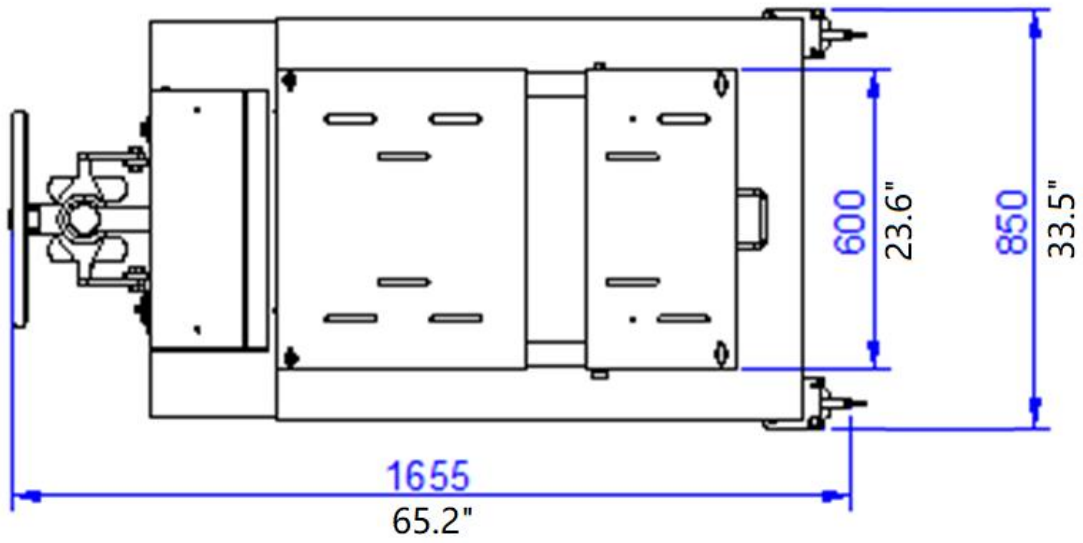

## **Receiving & Handling:**

**Unloading Lift Table Crate:** The Lift Table may be delivered with LTL lift gate service from the freight carrier, which a pallet jack or dolly with a minimum of 1,000 lb. capacity will only be required to remove crate from lift gate, in most cases. If not able to deliver with lift gate service, then a forklift or shop type crane able to support a minimum of 1,000 pounds will be required to offload from the back of freight carrier trailer. The lift table crate packaging weighs close to 1,000 pounds, not including any optional accessories that may be included.

## **Required Tools:**

- Pallet Jack or Fork Lift (Min. 1,000 lb. Capacity)
- Crow Bar / Hammer
- HD Scissors or Utility Knife
- Socket Wrenches with Ratchet
- Adjustable Wrench
- Philips Screwdriver
- Safety Glasses
- Gloves

## **Selecting Site:**

**NOTE:** Before assembling and operating your new lift table, ensure to check the following:

### **Overhead Obstructions:**

The area where the lift table will be operated should be free of any overhead obstructions such as heaters, building supports, electrical lines, etc.

### **Floor / Surface Requirements:**

Do not use lift table on asphalt or any type of soft surface. Concrete thickness & strength must meet requirement to safely support lift table and the load being applied. Also ensure lift table is used & operated on dry, grease free, level concrete surface. Do not operate lift table on concrete expansion seams or cracked, defective concrete.

**WARNING!!!:** Failure to adhere to foundation requirements may cause lift table instability, which could result in personal injury and/or property damages.

### **Operating Conditions:**

The lift table is not intended for outdoor use and has an operating ambient temp range of 41° - 104°F (5° - 40°C).

**CAUTION: DO NOT** use lift table outdoors unless special consideration has been made to protect from weather conditions. Placing the lift in a wet location, such as car wash bay, is prohibited and can void the warranty.

**WARNING!!!:** Operation or Use of the DC battery lift table is NOT permitted in explosion hazard areas or spaces.

### 3. Assembly Instructions

**WARNING!!** Improper assembly can cause accelerated wear, resulting in catastrophic failure which may cause property damage and / or bodily injury. Manufacturer will assume no liability for loss or damage of any kind, expressed or implied, resulting from improper installation or use of this product. Read this installation manual in its entirety before attempting to assemble or operate the lift table.

#### Step 1: Removal of Lift Table From Wooden Crate

**NOTE:** It is recommended removing lift table from wooden crate using a forklift, with a minimum of 1,000 lb. capacity. Lift table is elevated & secured to wooden blocks inside crate.

- 1) Using gloves, carefully remove banding straps secured around crate with heavy duty scissors or utility knife.
- 2) Remove lid, using a crow bar or hammer, beginning at one corner. Set aside, once removed.
- 3) Open one of the crates wide side walls, by bending all metal tabs at each corner end. Once metal tabs are aligned to tab holes, use hammer to help remove side wall from crate walls. Set aside, out of way, once removed.
- 4) Carefully remove the pallet jack dolly assembly from crate and set aside.
- 5) Use forklift to remove lift table from support blocks inside crate, ensuring to position forks width to be inside of support blocks and clear of caster wheels. Raise lift table using the underside the lift table frame, ensuring the forklift forks fully contact & support the whole frame.
- 6) Once lift table is slightly raised off support blocks, double check for any clearance issues, then carefully back lift table out of crate with forklift, and lower to the ground for assembly steps.

#### Step 2: Assemble Pallet Jack Dolly to Lift Table Base

- 1) Carefully position the **pallet jack dolly assembly** to brackets at the end of the lift table base. Place steel pivot ball on the top of piston rod and insert the rod into the **dolly bracket tube**. Secure piston rod to dolly bracket tube using **M10 x 20mm bolt**, Fig 1.

**NOTE:** Adjusting height of piston rod may be required to ensure the M10 bolt is secured into the groove of piston rod. Adjust piston rod height by pumping the dolly handle up & down.

- 2) Align connecting plates to lower bracket holes and secure using **M16 x 40mm bolts & lock nuts**.

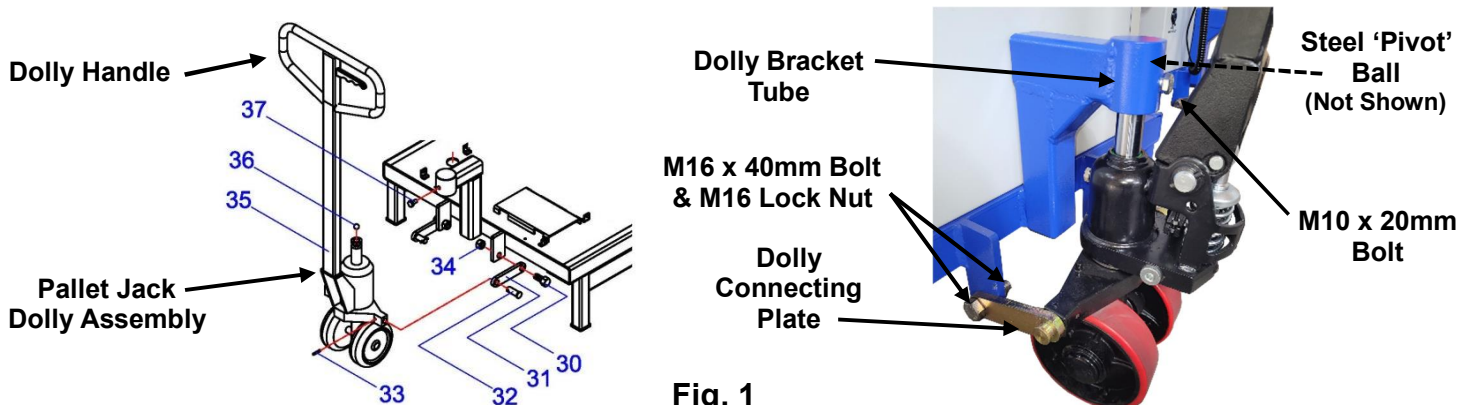

Fig. 1

7

### Step 3: Connecting Remote Hand Control Pendant to Control Box

**NOTE:** The remote hand control pendant may already be installed from the factory. If so, please skip below step.

- 1) Locate the **remote hand control pendant** from crate package and connect the 4 prong twist lock plug end to the threaded Hand Controller plug receptacle on the control box panel. Twist to tighten to secure together. Stow hand control pendant in the utility / tool tray, on the sides of control box, or on the lower sub-platform, utilizing the magnets on the backside of hand pendant. **Fig 2**

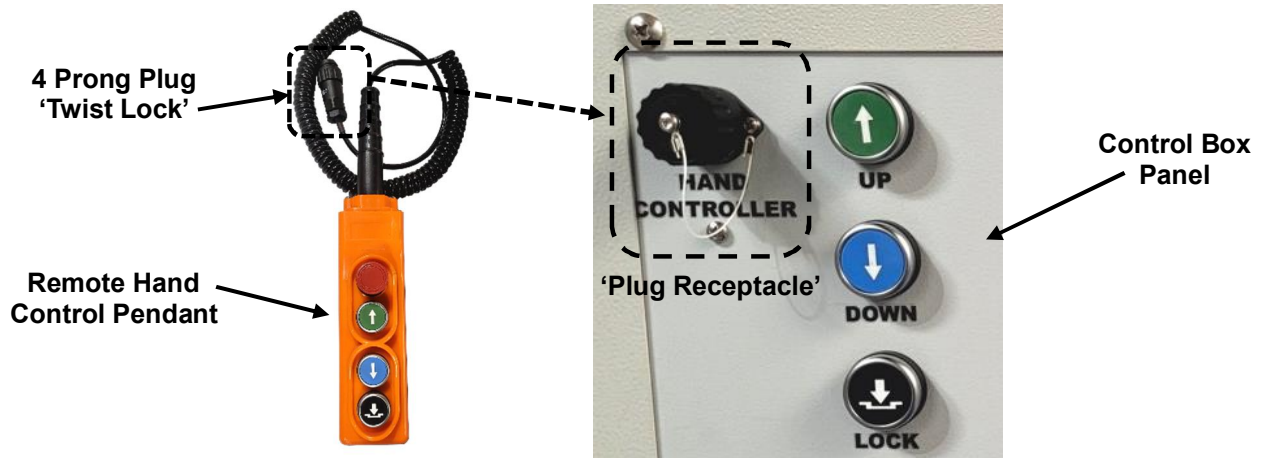

Fig. 2

**CAUTION:** Carefully position extra cord length for remote hand control pendant, so not to become a trip hazard and/or damaged by any components of lift table.

### Pre-Assembly From Factory:

- **Hydraulic Oil** has been added to the reservoir tank for the DC Power Unit from the factory. (Ref. 2.5 liters of AW32 Non-Detergent / Non-Foaming Anti-Wear Hydraulic Oil or equivalent.)
- A **Deep Cycle / Maintenance Free 12VDC Lead Battery** has been pre-installed inside the Control Box from the factory. (Model Ref. CSB/GPL 12520 12V 52Ah)

### Battery Charging Info:

- The Lift Table includes an integrated **Battery Charger** inside the control box & **Battery Level Indicator** located on the control box panel. After the **DC Battery Switch** is turned **ON** the **Battery Indicator** will provide the battery level status output capacity. **Green bars** indicate normal battery level output, **Yellow bars** for low output & **Red bars** for warning to recharge battery. **Fig. 3 'left'**
- To **Charge** the **12VDC Battery**, use the included **AC Power Cable** to plug into the **Power Inlet** socket, then set the **Control Switch** to the **CHARGE** mode position. **Fig. 3 'right'**

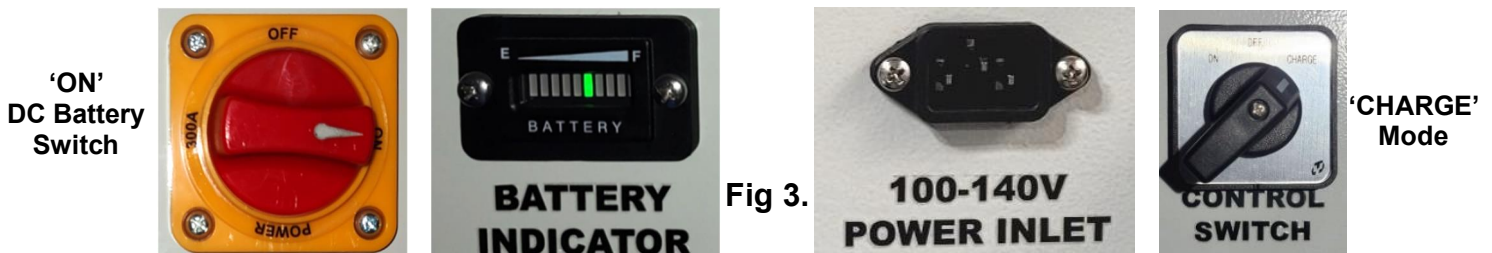

Fig. 3.



## 4. Start-Up / Testing

**CAUTION:** Prior to the Start-Up / Testing, visually inspect lift table for any signs of damages, defects and/or any missing or loose components. If any issues are discovered, DO NOT perform the Start-Up / Testing procedure, and contact the dealer to resolve.

**NOTE:** Perform Start-Up Test without placing a load on lift table.

### DC Battery System Operation Controls

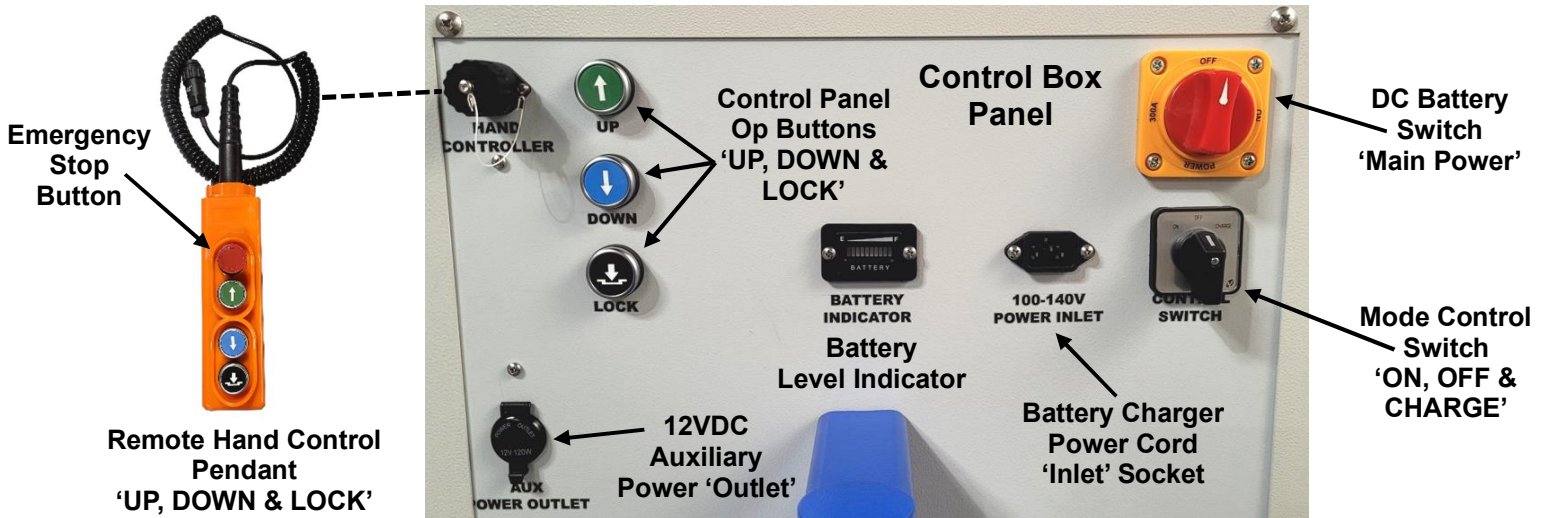

**IMPORTANT:** Check battery indicator to ensure the 12VDC Battery is fully charged for proper operation. If required, Charge Battery noted in the Battery Charging Info. section.

**NOTE:** Ensure the Remote Hand Control Pendant red Emergency Stop Button is in the disengaged 'up' position.

- A. Turn the red knob on the DC Battery Switch to the 'ON' position. (This provides main power to the 12VDC electrical system for battery status, lifting, lowering & latching operations.)
- B. Turn the black knob on the Control Switch to the 'ON' mode position. (This configures the 12VDC electrical system for ON, OFF or CHARGE function modes.)

*(Below Steps apply for either the Remote Hand Controller or Op Buttons on Control Panel)*

- C. Press the Green 'UP' Button to Raise. (The electric-hydraulic pump will prime hydraulic oil into the hydraulic cylinders and the lift table platform will begin to rise with safety latches passing over the welded safety latch blocks at the base of lift table frame. Ensure latches click together.)
- D. Press the Blue 'DOWN' Button to Lower. (The lift table will fully lower to the lowest height, as the hydraulic release valve is opened, and the safety latches are disengaged. NOTE: Slightly raise UP lift table to be off safety latches, prior to lowering using the DOWN Button.)
- E. Press the Black 'LOCK' Button to Lower onto Safety Latches. (The lift table's safety latches will engage, and the lift table will lower to the next lowest safety latch position.)
- F. Cycle Lift Table fully 'Up & Down' a couple of times. (This helps ensure all air is removed from the hydraulic system, while also helping to familiarize with the operational controls.)

**THE LIFT TABLE IS NOW READY FOR OPERATION**

## 5. Operation Instructions

**WARNING!!!:** Never exceed rated load capacity of lift table.

**CAUTION:** To avoid personal injury and/or property damage, permit only trained personnel to operate lift table.

**WARNING!!!:** Operation or Use of the DC battery lift table is NOT permitted in explosion hazard areas or spaces.

### Positioning, Lifting & Lowering

#### A. Remove & Lower a Heavy Component:

1. Follow the vehicle manufacturer's recommended service procedure for removal of the component.
2. Position the lift table under the vehicle's component to be serviced. On the front Control Panel turn the DC Battery Switch to the ON position, then the Control Switch to the ON mode position.
3. Raise the lift table's PT Platform to be near vehicle component. Apply locks to casters wheels.
4. Align the PT Platform to the bottom of the component, adjusting the PT Platform length using the 2ea Knob Screws & Handle. Adjust PT Platform's tilt angle, using the 3ea Jack Screws.
5. Carefully raise the lift table again to make contact with the component to support its weight.
6. Secure component to PT Platform using the included ratchet strap & eye bolts. **NOTE:** Eye bolts can be mounted to either the top or sides of the PT Platform.
7. Remove any remaining bolts from the vehicle component, now being supported by the lift table.
8. Lower the lift table, ensuring the vehicle component is properly supported & balanced.
9. Release caster wheel locks and carefully remove lift table from under vehicle.

#### B. Install & Raise a Heavy Component:

1. Follow the vehicle manufacturer recommended service procedure for installation of the component.
2. Secure the component on the lift table PT Platform first.
3. Position the lift table under a raised and fully supported vehicle chassis, typically using a two post or four post automotive lift.
4. Raise the lift table PT Platform so the component is close to the desired install position. If necessary, use Jack Screws to finely adjust the height & angle of the PT Platform to configure the component to the correct install position.
5. Follow the recommended service procedure for installing the component to vehicle.

#### C. Lift Table / Feature Tips: (LT-PT3300DC-X)

- A. Adjustable PT Platform 'Length'** - the small section of the PT Platform is extendable, secured with two knob screws, allowing flexibility to better configure & support component loads.

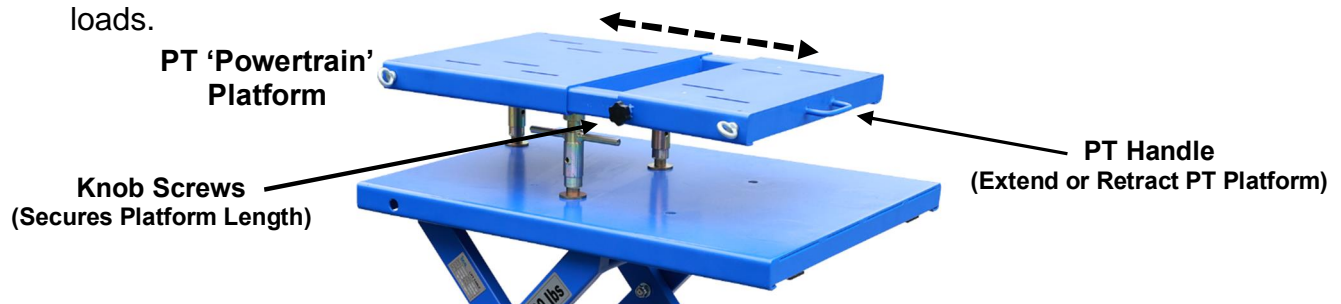

LT-PT3300DC-X  
MAR 2024

**B. Adjustable PT Platform ‘Tilt Angle’** - the 2+adjustable Jack Screws can be rotated so that the upper PT Platform can be slightly tilted lengthwise by 6° and widthwise by 8° providing flexibility to better configure component to vehicle.

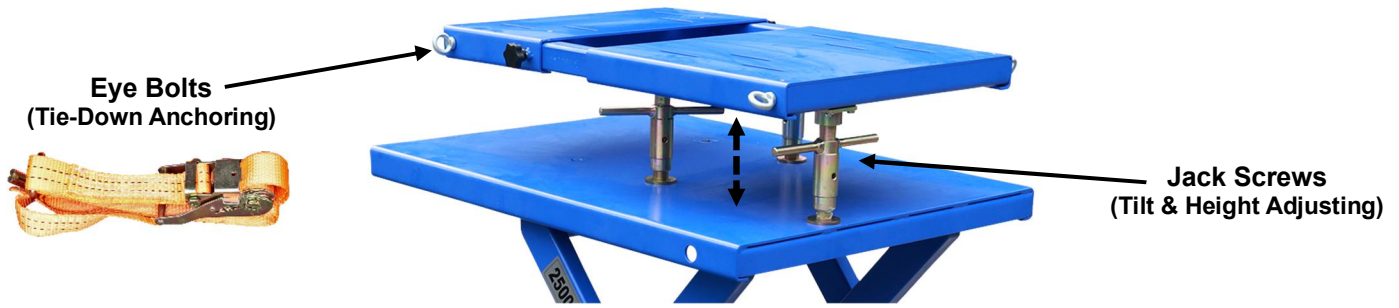

**C. Maneuvering Lift Table with Pallet Jack Dolly** - the Pallet Jack Dolly with 6+Poly Caster Wheels provides smooth & quick lift table mobility. Pumping the Dolly Handle up & down raises the backside of lift table, allowing to either push or pull the lift table into position. Once in position, always use Release Lever to lower lift table back onto the rear Leg Support Stands.

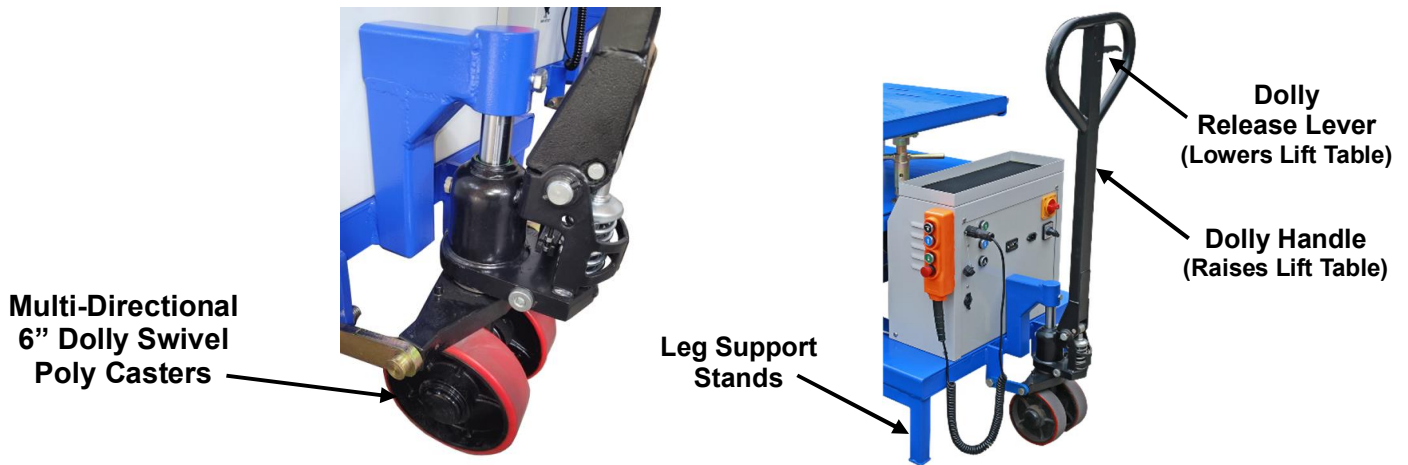

**D. Adjustable Lift Table 6” ‘Poly Caster Wheels’** - the front Caster Wheels include directional locks, allowing the option to either swivel or be locked into a fixed position. This is simply done by pulling out the ring tab & rotating the pin inside the square tube.

- With the Direction Caster Pin pulled-out the Caster Wheels swivels freely, allowing the lift table to be moved laterally.
- With Direction Caster Pin inserted-in the Caster Wheel direction will be locked in place.

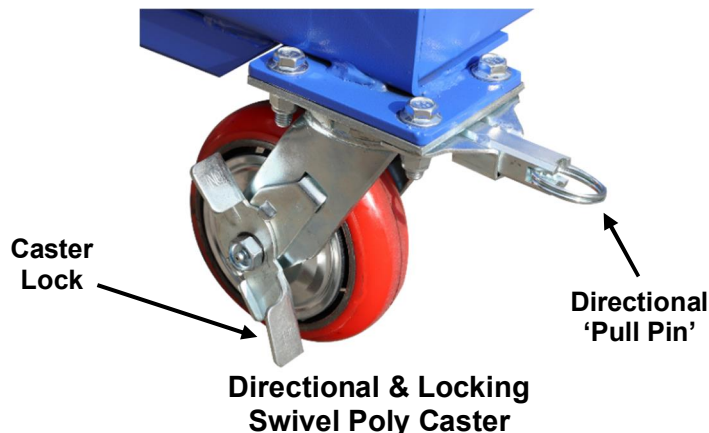

**WARNING:** Never Operate the Lift Table if the Safety Latch Mechanism is not working properly.

## 6. Trouble-Shooting

Common lift table issues may be encountered over time. Please see probable causes & possible solutions covered in the paragraphs below. If the troubleshooting guide does not provide assistance to resolve the lift table issue(s), please contact the dealer / distributor for assistance.

**WARNING!! Failure to properly relieve Hydraulic pressure in the following steps can cause possible injury to personnel. Call for Technical assistance guidance, if needed.**

### 1. DC Power Unit Does Not Run:

- A. Blown fuse or circuit breaker.....Replace the fuse or reset the circuit breaker.
- B. Too low battery voltage..... Charge the battery.
- C. Charger or battery fails.....Replace with a new charger or battery.
- D. Motor winding burned out.....Replace the motor.

### 2. DC Power Unit Runs but Will Not Raise:

- A. Oil level too low.....Oil level should be at the MAX Fill Line with table fully lowered.
- B. The lowering valve is not closed.....Clean or replace the lowering valve.
- C. The pump sucks in air .....Replace the inlet pipe or re-tighten it.

### 3. DC Power Unit Runs but Will Not Raise Vehicle:

- A. Over loading .....Check the loading weight and/or balance the weight distribution.
- B. Low battery voltage.....Charge the battery fully.
- C. Lowering valve not closed.....Clean or replace the lowering valve.
- D. Relief valve opens in advance.....Reset or replace pressure relief valve.

### 4. Oil Blows Out Oil Reservoir Fill Cap:

- A. Oil reservoir overfilled.....Fill up at the Max line only when lift is fully collapsed.
- B. Lift lowered too quickly while under a heavy load.....Lower down with stops.

### 5. DC Power Unit Hums and Will Not Run:

- A. Lift overloaded..... Remove excessive weight from lift loading.
- B. Bad gear pump.....Call for repair or replace with a new pump.

### 6. Lift Jerks Up and Down:

- A. Air in hydraulic system.....Fully raise lift table & return low height. \*Repeat 2-3 times.  
(Apply in intervals 2 mins apart min., not to overheat DC power unit.)

### 7. Oil Leaks:

- A. (Inside control box) Reservoir tank mount flange..ō .....Too much hydraulic oil.
- B. Rod end of hydraulic cylinder.....Replace the rod seal or cylinder.
- C. At hose or fitting connector.....Inspect & tighten first, reinspect & replace, if required.

### 8. Lift Makes Excessive Noise:

- A. Roller assemblies not moving freely.....Inspect and apply grease.
- B. Check for excessive wear on shafts & pins.....Inspect and replace, as required.
- C. Seals are dry in hydraulic cylinder(s).....Cycle lift as noted in above #6.

### 9. Lift Will Not Lower:

- A. Lock Latches Engaged.....Before lowering down, raise up a little first.
- B. Defective Release valve electro-magnet.....Inspect and replace.
- C. Defective safety latch mechanismō .....Inspect and replace.

## 7. Inspection, Maintenance & Cleaning

**CAUTION:** Failure to perform the pre-operational inspection checks, maintenance & cleaning can result in expensive product damage, lost production time, and possible personal injury.

**WARNING!!!:** Always turn off the main power & control mode switches on front of the control panel before performing any inspection, adjustments, maintenance and/or cleaning.

### Before Each Use: (Pre-Operation Checks)

Inspect the general condition of the Lift Table for any possible issues that may affect the lift table's safe operation:

1. Inspect for any loose screws, misalignment / binding of moving components, broken or damaged parts, including cables, fittings & hoses.
2. Inspect for any hydraulic system external leakages.
3. Inspect to ensure the DC electrical system controls & safety latches are working properly.
4. Inspect that pallet jack dolly & caster wheels are not damaged and are working properly.
5. Inspect to ensure the 12VDC battery is sufficiently charged for proper operation.

**WARNING!!!:** If a noise is heard not associated with normal lift operation, or if there is any indications of impending lift table failure, **CEASE OPERATION IMMEDIATELY!** Inspect, correct and/or replace damaged or defective parts as required. Failure to heed this warning can result in serious injury, death, or damage to equipment.

### Maintenance:

#### WEEKLY:

- Inspect and use premium quality shop grease to lubricate all moving parts using the grease zerks provided on lift table, if required.
- Inspect control box, control panel switches & buttons and remote hand controller for any damages, loose connections, or defects.

#### YEARLY:

- With the lift fully lowered, remove the control box / panel to check hydraulic oil level for the hydraulic reservoir tank is close to the Max Fill Line. If not, add premium quality AW32 or equivalent oil until the level is even with the Max Fill Line. After filling, replace the Plug back on reservoir tank.

**CAUTION: Never Add Hydraulic Fluid while Lift Table is in the raised position!**

- Remove control box / panel to inspect 12VDC battery, battery charger & electrical connections and wiring to be free of defects, corrosion and are sufficiently secured.
- Check for any excessive wear of scissors, lifting platforms, safety latch mechanism, rubber contact & height adaptor pads. Replace, if necessary.

### Cleaning:

- With compressed air or vacuum, remove all dirt and debris from the lift table & casters. Use a detergent or mild solvent to remove any grease or oil grease from lift table.

# Exploded Views

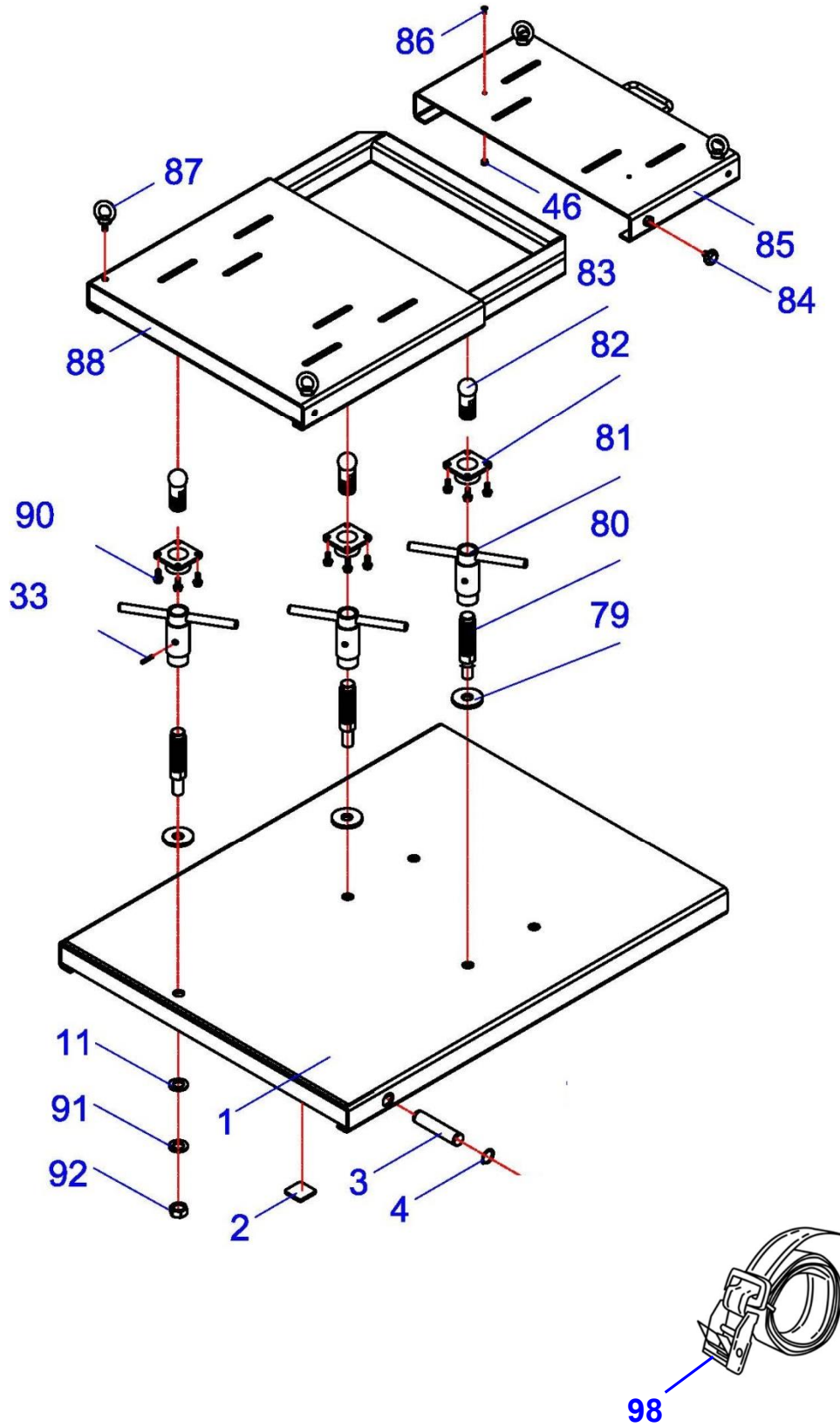

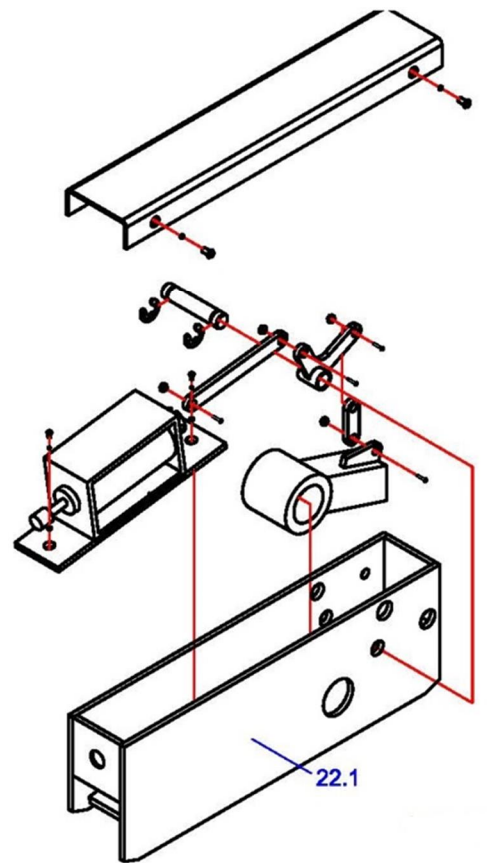
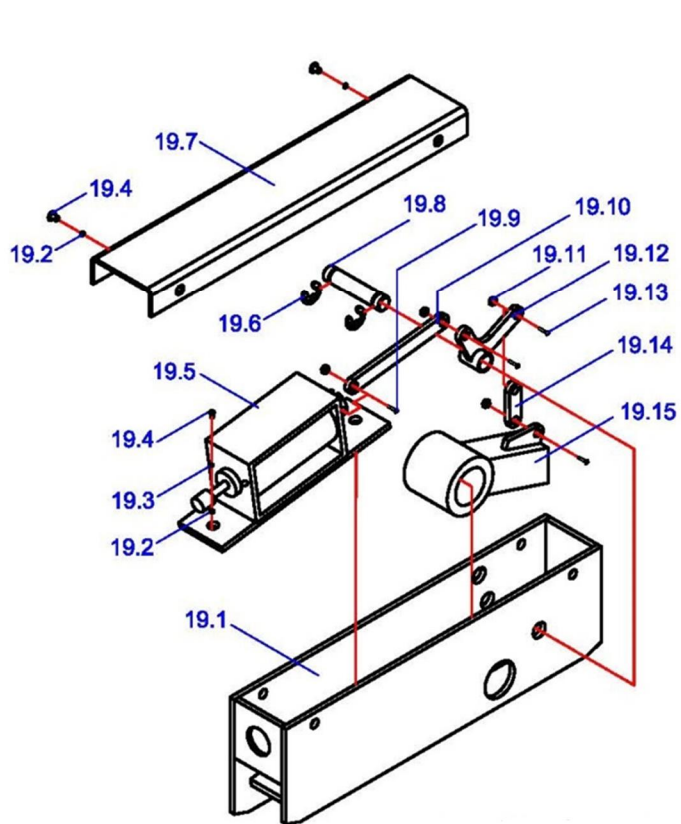
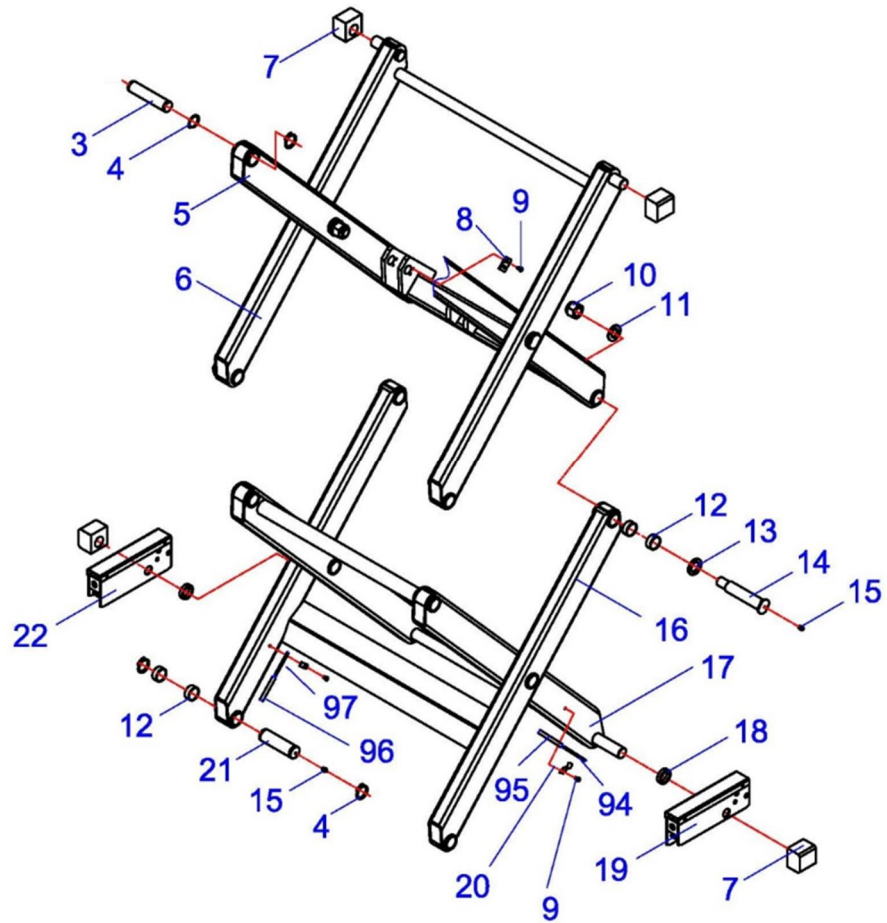

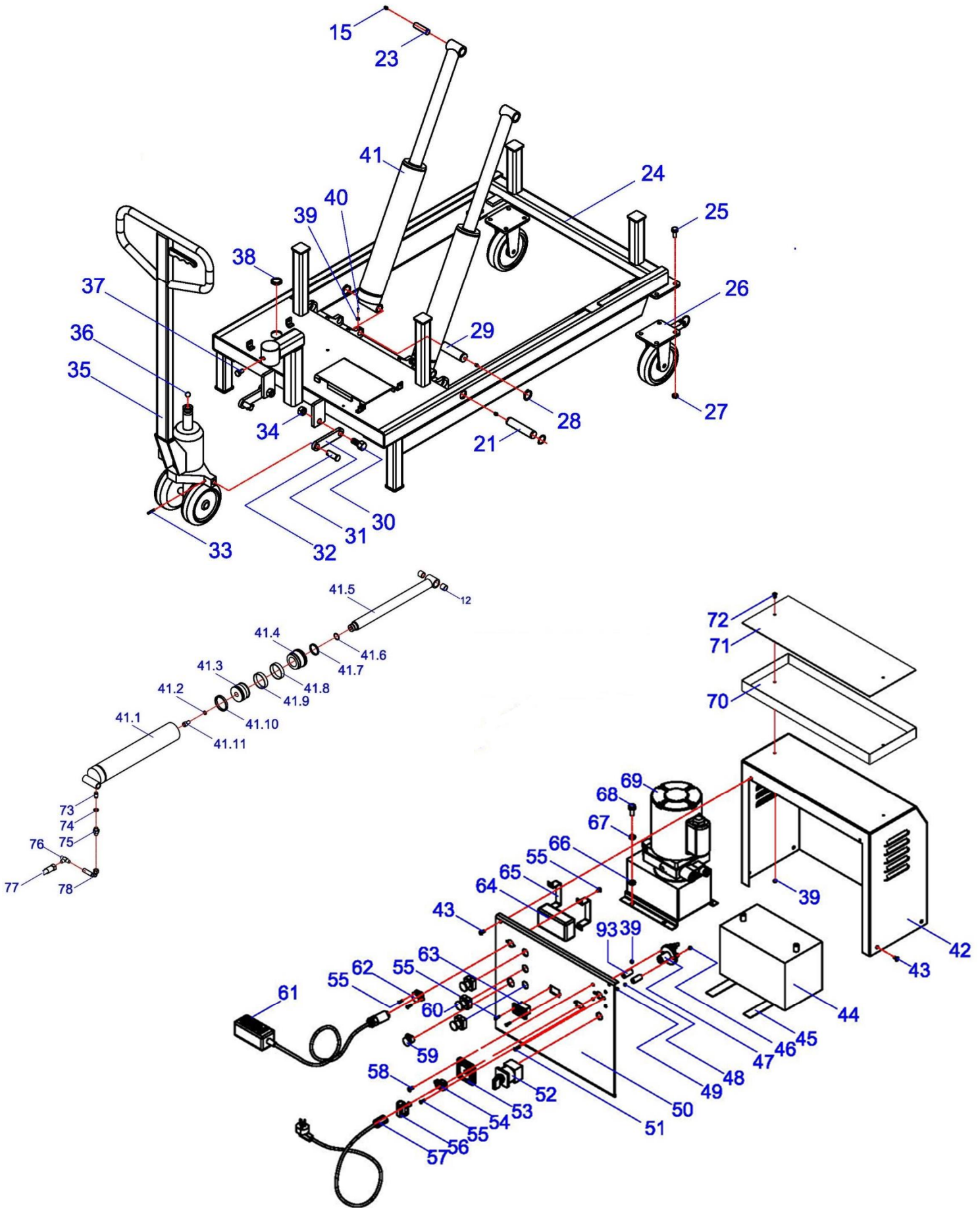



# (12VDC Circuit Diagram)

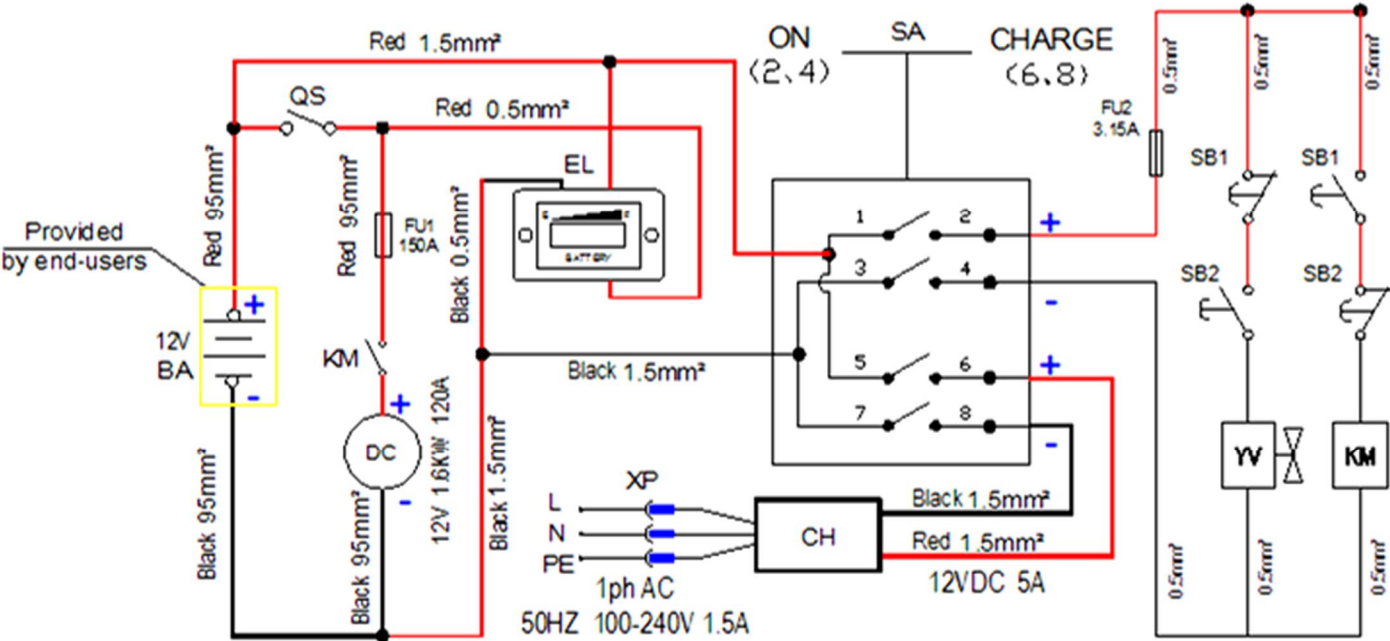

1	BA	Battery
2	QS	Power Switch
3	KM	DC Contactor
4	DC	DC Motor
5	EL	Battery Indicator
6	CH	Charger
7	YV	Lowering Valve
8	SB2	Down Button
9	SB1	Up Button
10	FU1	Fuse -1
11	FU2	Fuse -2
12	XP	Power Cable
13	SA	Select Switch

## Parts List

ITEM	TUX P/N	M-REF P/N	DESCRIPTION	QTY.
1	LT-3300DCX-001	YP01-01000-D00	Main Platform (LT3300-DCX)	1
2	LT-3300DCX-002	YP01-00009-H00	Rubber Adhesive Pad	4
3	LT-3300DCX-003	YP01-00002-000	Upper Axle	2
4	LT-3300DCX-004	5304-00025-000	Circlip, D25	8
5	LT-3300DCX-005	YP01-07000-000	Upper / Inside Scissor Frame	1
6	LT-3300DCX-006	YP01-08000-D00	Upper / Outside Scissor Frame	1
7	LT-3300DCX-009	YP01-00001-000	Nylon Sliding Guide Block	4
8	LT-3300DCX-007	JP24-00032-000	Fixing Plate	2
9	LT-3300DCX-008	5110-06010-000	Screw, M6 x 10mm	10
10	LT-3300DCX-010	5206-00020-000	Lock Nut, M20	8
11	LT-3300DCX-011	5302-00020-000	Flat Washer, D20	11
12	LT-3300DCX-012	5603-25025-000	Bearing, D25 x D28 x 25mm	42
13	LT-3300DCX-013	5302-00025-000	Flat Washer, D25	8
14	LT-3300DCX-014	JP24-00003-000	Pivot Bolt	8
15	LT-3300DCX-015	JP02-00007-000	Grease Zerk, M6	14
16	LT-3300DCX-016	YP01-05000-000	Lower / Outside Scissor Frame	1
17	LT-3300DCX-017	YP01-06000-G00	Lower / Inside Scissor Frame	1
18	LT-3300DCX-018	YP01-00003-H00	Spacer Sleeve	2
19	LT-3300DCX-019	JP24-13000-000	Safety Latch (RH)	1
19.1	LT-3300DCX-019.1	JP24-13100-000	Latch Frame (RH)	1
19.2	LT-3300DCX-019.2	5302-00005-000	Flat Washer, D5	8
19.3	LT-3300DCX-019.3	5303-00005-000	Lock Washer, D5	4
19.4	LT-3300DCX-019.4	5110-05012-000	Screw, M5 x 12mm	8
19.5	LT-3300DCX-019.5	YP01-12000-E00	Electromagnet	2
19.6	LT-3300DCX-019.6	5305-00006-000	Circlip, D6	4
19.7	LT-3300DCX-019.7	JP24-00016-000	Latch Cover	2
19.8	LT-3300DCX-019.8	JP24-13003-000	Latch Pin	3
19.9	LT-3300DCX-019.9	5110-04020-000	Screw, M4 x 20mm	2
19.10	LT-3300DCX-019.10	JP24-13001-000	Linkage Arm - Long	2
19.11	LT-3300DCX-019.11	5206-00004-000	Lock Nut, M4	8
19.12	LT-3300DCX-019.12	JP24-13200-000	Rocker Arm	2
19.13	LT-3300DCX-019.13	5110-04012-000	Screw, M4 x 12mm	6
19.14	LT-3300DCX-019.14	JP24-13002-000	Linkage Arm - Short	2
19.15	LT-3300DCX-019.15	JP24-13300-000	Latch	2
20	LT-3300DCX-020	JP24-00009-000	Lock Plate	10
21	LT-3300DCX-021	YP01-00003-000	Lower Pivot Shaft	2
22	LT-3300DCX-022	JP24-14000-000	Safety Latch (LH)	1
22.1	LT-3300DCX-022.1	JP24-14100-000	Latch Frame (LH)	1
23	LT-3300DCX-023	JP24-00023-001	Cylinder, Short Axle	2
24	LT-3300DCX-024	YP01-04000-D00	LT Base Frame (LT-3300DC-X)	1
25	LT-3300DCX-025	5117-10035-000	Flange Bolt, M10 x 35mm	6
26	LT-3300DCX-026	YP01-00007-000	6+Poly Caster (Swivel Lock & Brake)	2
27	LT-3300DCX-027	5210-00010-000	Flange Lock Nut, M10	6
28	LT-3300DCX-028	5304-00020-000	Circlip, D20	4
29	LT-3300DCX-029	JP24-00024-000	Cylinder, Long Axle	2
30	LT-3300DCX-030	5101-16040-000	Bolt, M16 x 40mm	2
31	LT-3300DCX-031	YP01-00005-000	Dolly Connecting Plate	2
32	LT-3300DCX-032	DJ03-00005-000	Dolly Pin	2
33	LT-3300DCX-033	5402-05030-000	Cotter Pin, D5 x 30mm	5

34	LT-3300DCX-034	5206-00016-000	Lock Nut, M16	2
35	LT-3300DCX-035	DJ01-15000-100	Pallet Jack Dolly Assy.	1
36	LT-3300DCX-036	5601-01905-000	Steel Pivot Ball	1
37	LT-3300DCX-037	5102-10020-000	Bolt, M10 x 20mm	1
38	LT-3300DCX-038	SJ01-00017-000	Protection Ring	1
39	LT-3300DCX-039	5206-00005-000	Lock Nut, M5	8
40	LT-3300DCX-040	5109-05014-000	Threaded Pin, M5 x 14mm	2
41	LT-3300DCX-041	YP01-05000-G00	Hydraulic Cylinder	2
41.1	LT-3300DCX-041.1	YP01-05100-G00	Cylinder Body	1
41.2	LT-3300DCX-041.2	5303-00012-000	Lock Washer, D12	1
41.3	LT-3300DCX-041.3	YP01-05002-G00	Piston	1
41.4	LT-3300DCX-041.4	YP01-05003-G00	Guide Ring	1
41.5	LT-3300DCX-041.5	JP24-04200-000	Piston Rod	1
41.6	LT-3300DCX-041.6	5901-00244-000	O-Ring, D24.4 x D3.1	1
41.7	LT-3300DCX-041.7	5906-00040-000	Dust Ring, D40	1
41.8	LT-3300DCX-041.8	JP24-04008-000	Guide Ring - A, D40 x D45 x 15mm	1
41.9	LT-3300DCX-041.9	YP01-05001-G00	Guide Ring - B, D55 x D60 x 15mm	1
41.10	LT-3300DCX-041.10	5905-00050-000	Seal, D50 x D60 x 7.3mm	1
41.11	LT-3300DCX-041.11	5105-12020-000	Screw, M12 x 20mm	1
42	LT-3300DCX-042	SL02-00035-A00	Control Box Case (LT-3300DCX)	1
43	LT-3300DCX-043	5115-06012-000	Screw, M6 x 12mm	6
44	LT-3300DCX-044	BZ23-00001-000	DC Battery, 12VDC, 52AH (Sealed Pb)	1
45	LT-3300DCX-045	SL02-00049-A00	Nylon Tie Strap	2
46	LT-3300DCX-046	5206-00006-000	Lock Nut, M4	4
47	LT-3300DCX-047	BZ22-05503-000	Battery Switch	1
48	LT-3300DCX-048	5202-00004-000	Nut, M4	8
49	LT-3300DCX-049	5302-00004-000	Flat Washer, D4	8
50	LT-3300DCX-050	YP01-11000-Q00	Switch Panel	1
51	LT-3300DCX-051	5110-06045-000	Screw, M6 x 45mm	2
52	LT-3300DCX-052	DJ04-20001-100	Select Switch	1
53	LT-3300DCX-053	DJ02-00017-A00	Battery Switch Cover Plate	1
54	LT-3300DCX-054	SL02-00041-A00	Power Socket (Inlet 100-140V)	1
55	LT-3300DCX-055	5110-04016-000	Screw, M4 x 16mm	8
56	LT-3300DCX-056	DJ02-00018-A00	Switch Knob	1
57	LT-3300DCX-057	BZ23-00003-A00	Power Cord (Battery Charger)	1
58	LT-3300DCX-058	5110-05014-000	Screw, M5 x 14mm	4
59	LT-3300DCX-059	QK04-08002-FJ5	Aux Power Socket (12VDC / 120W)	1
60	LT-3300DCX-060	DJ02-20002-GRN	Operation $\uparrow$ UpqButton, Green	1
60.1	LT-3300DCX-060.1	DJ02-20002-BLU	Operation $\downarrow$ DownqButton, Blue	1
60.2	LT-3300DCX-060.2	DJ02-20002-BLK	Operation $\downarrow$ LockqButton, Black	1
61	LT-3300DCX-061	MK01-00200-000	Remote Hand Control Pendant	1
62	LT-3300DCX-062	BZ23-08000-M00	Socket Plug	1
63	LT-3300DCX-063	BZ23-00003-000	Battery Indicator	1
64	LT-3300DCX-064	SL02-00041-A00	Battery Charger	1
65	LT-3300DCX-065	SL02-00057-A00	Battery Charger Bracket	2
66	LT-3300DCX-066	5302-00008-000	Flat Washer, D8	4
67	LT-3300DCX-067	5306-00008-000	Spring Washer, D8	4
68	LT-3300DCX-068	5102-08016-000	Bolt, M8 x 16mm	4
69	LT-3300DCX-069	DBZ23A-00	12VDC, 1.6Kw Power Unit (LT-3300DCX)	1
70	LT-3300DCX-070	SL02-00054-A00	Tool Tray (LT-3300DCX)	1
71	LT-3300DCX-071	SL02-00056-A00	Tool Tray, Rubber Pad (LT-3300DCX)	1
72	LT-3300DCX-072	5110-05014-000	Screw, M5 x 14mm	2
73	LT-3300DCX-073	JP24-04005-000	Pressure Compensating Valve	2

74	LT-3300DCX-074	5903-00014-000	Combined Washer, D14	2
75	LT-3300DCX-075	JP24-04006-000	Oil Fitting	4
76	LT-3300DCX-076	SJ01-00016-000	T-Fitting	1
77	LT-3300DCX-077	LJ03-00010-000	Hydraulic Hose, (30"L)	1
78	LT-3300DCX-078	YP01-00010-G00	Short Hose w/ 90° End, (9±L)	2
79	LT-PT3300DCX-079	YP01-09004-000	Jack Screw, Large Washer	3
80	LT-PT3300DCX-080	YP01-10002-D00	Jack Screw, Threaded Rod	3
81	LT-PT3300DCX-081	YP01-10100-D00	Jack Screw, T-Bar Body	3
82	LT-PT3300DCX-082	YP01-07001-000	Jack Screw, Ball Head Bracket	3
83	LT-PT3300DCX-083	YP01-10001-D00	Jack Screw, Ball Head Bar	3
84	LT-PT3300DCX-084	YP01-10020-000	Knob Screw, M10 x 20mm	2
85	LT-PT3300DCX-085	YP01-03000-G00	PT <del>Sliding</del> Table Platform	1
86	LT-PT3300DCX-086	5202-06012-000	Screw, M6 x 12mm	2
87	LT-PT3300DCX-087	5103-08025-000	Eye Bolt, M10 x 16mm	4
88	LT-PT3300DCX-088	YP01-02000-G00	PT <del>Fixed</del> Table Platform	1
90	LT-PT3300DCX-090	5117-08020-000	Screw, M8 x 20mm	12
91	LT-3300DCX-091	5306-00020-000	Lock Washer, D20	3
92	LT-3300DCX-092	5202-00020-000	Nut, M20	11
93	LT-3300DCX-093	DJ02-00006-A00	Fixing Tube	2
94	LT-3300DCX-094	YP01-00001-E00	Latch Cable #1 (75±)	1
95	LT-3300DCX-095	YP01-00002-E00	Cable Spring Cover #1 (63±)	1
96	LT-3300DCX-096	YP01-00003-E00	Latch Cable #2 (39±)	1
97	LT-3300DCX-097	YP01-00004-E00	Cable Spring Cover #2 (53±)	1
98	LT-PT3300DCX-098	JP24-00016-FJ6	Tie-Down Ratchet Strap	1

# LIMITED WARRANTY

## Structural Warranty:

The following parts and structural components carry a five-year warranty:

Columns	Arms	Uprights	Swivel Pins
Legs	Carriages	Overhead Beam	
Tracks	Cross Rails	Top Rail Beam	

## Limited One-Year Warranty:

Tuxedo Distributors, LLC (iDEAL) offers a limited one-year warranty to the original purchaser of Lifts and Wheel Service equipment in the United States and Canada. Tuxedo will replace, without charge, any part found defective in materials or workmanship under normal use, for a period of one year after purchase. The purchaser is responsible for all shipping charges. This warranty does not apply to equipment that has been improperly installed or altered or that has not been operated or maintained according to specifications.

## Other Limitations:

This warranty does not cover:

1. Parts needed for normal maintenance
2. Wear parts, including but not limited to cables, slider blocks, chains, rubber pads and pulleys
3. Replacement of lift and tire changer cylinders after the first 30 days. A seal kit and installation instructions will be sent for repairs thereafter.
4. On-site labor

Upon receipt, the customer must visually inspect the equipment for any potential freight damage before signing clear on the shipping receipt. Freight damage is not considered a warranty issue and therefore must be noted for any potential recovery with the shipping company.

The customer is required to notify Tuxedo of any missing parts within 72 hours. Timely notification must be received to be covered under warranty.

Tuxedo will replace any defective part under warranty at no charge as soon as such parts become available from the manufacturer. No guarantee is given as to the immediate availability of replacement parts.

Tuxedo reserves the right to make improvements and/or design changes to its lifts without any obligation to previously sold, assembled, or fabricated equipment.

There is no other express warranty on the Tuxedo lifts and this warranty is exclusive of and in lieu of all other warranties, expressed or implied, including all warranties of merchantability and fitness for a particular purpose.

To the fullest extent allowed by law, Tuxedo shall not be liable for loss of use, cost of cover, lost profits, inconvenience, lost time, commercial loss or other incidental or consequential damages.

This Limited Warranty is granted to the original purchaser only and is not transferable or assignable.

Some states do not allow exclusion or limitation of consequential damages or how long an implied warranty lasts, so the above limitations and exclusions may not apply. This warranty gives you specific legal rights and you may have other rights, which may vary from state to state.

8320 E Hwy 67, Alvarado, TX 76009  
Ph. 817-558-9337 / Fax 817-558-9740